



SISTEMA DE GESTIÓN DE COMBUSTIBLE



DISPENSADORES



KITS



BOMBAS



MEDIDORES



PISTOLAS

PANTHER DC

CARACTERÍSTICAS

- ESTRUCTURA ROBUSTA
- FÁCIL DE INSTALAR
- DISEÑO COMPACTO
- IP55

La PANTHER DC es una bomba giratoria de paletas con cebado automático, idónea para todas aquellas aplicaciones en las que se precisa un caudal importante. Incluye un filtro de 100 µ y una válvula de derivación. La versión de 24/12 V puede utilizarse con ambas tensiones.

RENDIMIENTO

HASTA

70 L/MIN

CAUDAL

12/24V

TENSIÓN
ALIMENTACIÓN

30 MIN

CICLO DE SERVICIO



PANTHER DC



ASSA
INGENIERÍA, CALIDAD, INNOVACIÓN

PACKAGING

| CÓDIGO | PESO | | PACKAGING | | |
|-----------|------|------|-------------|-------------|-----------|
| | KG | LBS | MM | PULGADAS | UDS./CAJA |
| FO034000B | 7,5 | 16,5 | 345X175X255 | 13,6X6,9X10 | 1 |
| FO034001B | 7,5 | 16,5 | 345X175X255 | 13,6X6,9X10 | 1 |
| FO034100C | 7,5 | 16,5 | 345X175X255 | 13,6X6,9X10 | 1 |
| FO034101C | 7,5 | 16,5 | 345X175X255 | 13,6X6,9X10 | 1 |
| FO034116C | 7,5 | 16,5 | 345X175X255 | 13,6X6,9X10 | 1 |



FILTRACIÓN



MONITOREO DE DEPÓSITO



ENROLLADORES DE MANGUERA



ACCESORIOS



MATERIAL PROMOCIONAL



AIRE



ANTICONG.



AdBlue®



BIODIÉSEL



DIÉSEL



ALIMENTOS



GASOLINA



GRASA



QUEROSENO



ACEITE



AGUA



LIMPIAPARAB.

GRÁFICO

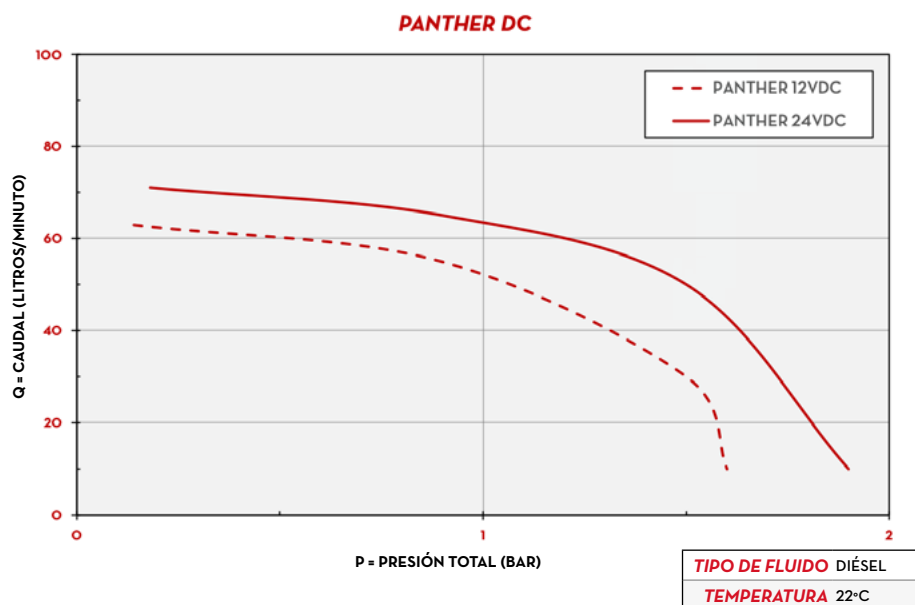

DIMENSIONES

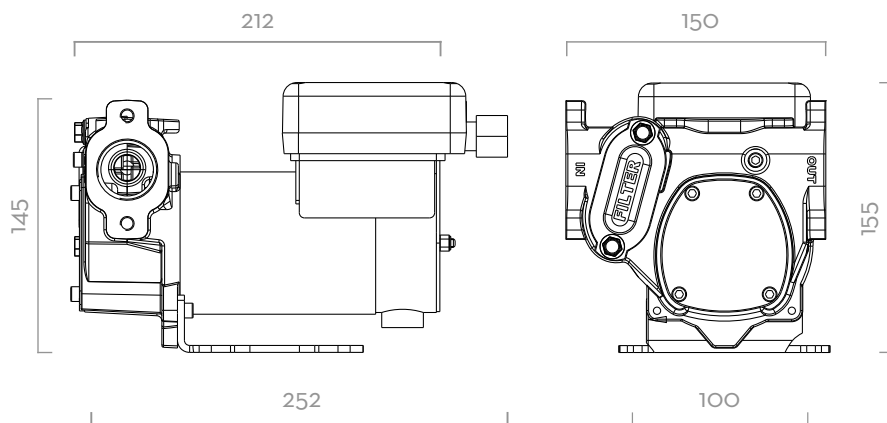

Las dimensiones se expresan en milímetros

CONTENIDO DE LA CAJA

- BOMBA PANTHER DC
- MANUAL DE INSTRUCCIONES

DETALLES



INTERRUPTOR ON/OFF



ROSCA DE 1" BSP



FILTRO INTEGRADO

MATERIALES

- CUERPO: HIERRO FUNDIDO
- ROTOR: ACERO SINTERIZADO
- PALETAS: RESINA ACETÁLICA
- MOTOR: CARCASA DE ALUMINIO



BOMBA

- > MÁX. 6 M (20 FT),
- > MANGUERA DE SUCCIÓN Ø 1" MÍN.,
- > ALTURA MÁX. DE SUCCIÓN:
 - 2M (7FT) SIN VÁLVULA ANTIRRETORNO
 - 4M (14FT) CON VÁLVULA ANTIRRETORNO



DEPÓSITO

FICHA TÉCNICA

| CÓDIGO | DESCRIPCIÓN | TIPO DE FLUIDO | CAUDAL | | TENSIÓN | | | CICLO DE SERVICIO | RPM | SALIDA |
|-----------|---------------------------------------|----------------|---------|------------|---------|-----------------|-----------|-------------------|-------------|--------|
| | | | L/MIN | GPM | VOLT CC | POTENCIA/VATIOS | AMP. MÁX. | | | |
| FO034000B | PANTHER DC 12V | D | 56 | 14,8 | 12 | 300 | 35 | 30 | 2900 | 1" |
| FO034001B | PANTHER DC 12V W/CABLE 2MT W/PLIERS | D | 56 | 14,8 | 12 | 300 | 35 | 30 | 2900 | 1" |
| FO034100C | PANTHER DC 24/12V | D | 70 / 35 | 18,5 / 9,2 | 24/12 | 420 / 150 | 25 / 16 | 30 | 3600 / 1800 | 1" |
| FO034101C | PANTHER DC 12/24V W/CABLE 2MT W/CLIPS | D | 70 / 35 | 18,5 / 9,2 | 24/12 | 420 / 150 | 25 / 16 | 30 | 3600 / 1800 | 1" |
| FO034116C | PANTHER DC 12/24V W/CABLE 4MT W/CLIPS | D | 70 / 35 | 18,5 / 9,2 | 24/12 | 420 / 150 | 25 / 16 | 30 | 3600 / 1800 | 1" |

PANTHER DC