



LLENADO DE  
VEHÍCULOS



SISTEMA DE GESTIÓN  
DE COMBUSTIBLE



KITS



BOMBAS



MEDIDORES



MEDIDORES  
PARA PISTOLA

# SUZZARABLUE PORTABLE KIT

## CARACTERÍSTICAS

- LISTO PARA USAR
- TRANSPORTABLE
- PINZAS DE CONEXIÓN DE BATERÍA

La facilidad de uso es la principal característica del PIUSI SUZZARABLUE PORTABLE KIT. La versión básica de todos los dispensadores de Adblue®: se compone de la bomba SUZZARABLUE y la pistola manual SUZZARABLUE MANUAL NOZZLE.

## RENDIMIENTO

HASTA

**35 L/MIN**

DE CAUDAL

**CA/CC**  
TENSIÓN

DE ALIMENTACIÓN

**20 MIN**

DE CICLO DE SERVICIO



SUZZARABLUE PORTABLE KIT



## PACKAGING

CÓDIGO	PESO		PACKAGING		N. BOXES / EUROPALLET	
	KG	LBS	MM	UDS./CAJA		
FOO201AAA	8	17,6	357X327X275	1	24	36
FOO201C7A	10	22	357X327X275	1	24	36



PISTOLAS



FILTRACIÓN



MONITOREO DE DEPÓSITO



ENROLLADORES DE MANGUERA



ACCESORIOS



MATERIAL PROMOCIONAL



CONEXIÓN DE AIRE



ANTI-CONGELANTE



AdBlue®



BIODIÉSEL



GASÓLEO



ALIMENTOS



GASOLINA



GRASA



QUEROSENO



ACEITE



AGUA



LIMPIA-PARA-BRISAS

## GRÁFICOS

### SUZZARABLUÉ AC/DC

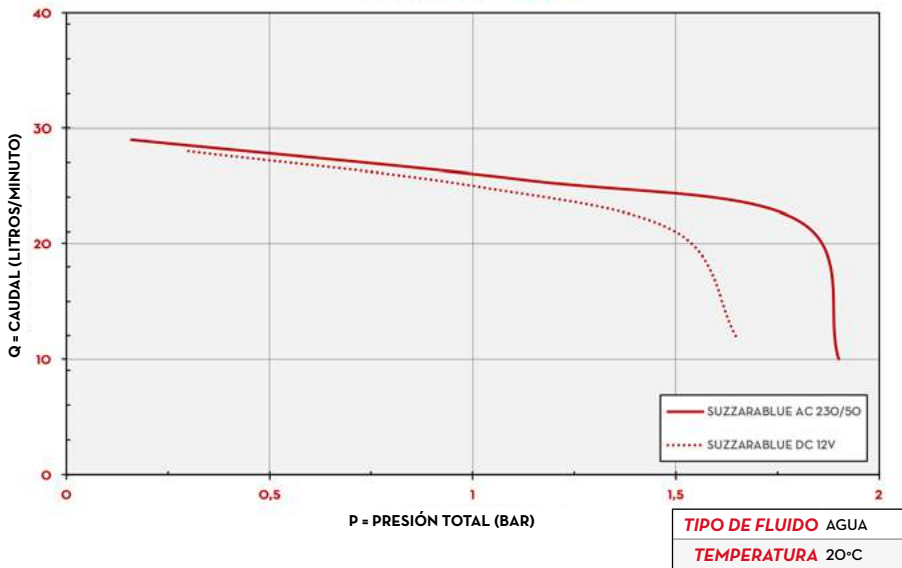

## DIMENSIONES

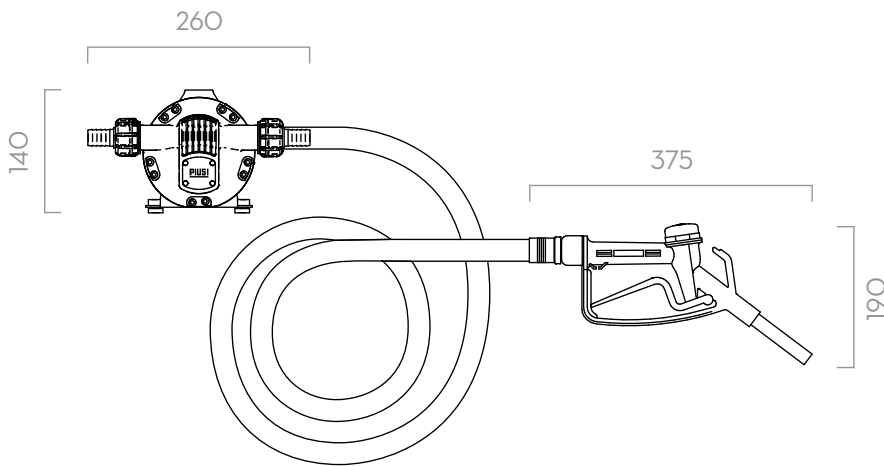

Las dimensiones se expresan en milímetros

## CONTENIDO DE LA CAJA

- BOMBA SUZZARABLUÉ PUMP AC/DC
- PISTOLA MANUAL
- VÁLVULA DE FONDO
- MANGUERA DE SUCCIÓN / SUMINISTRO
- MANUAL DE INSTRUCCIONES

## DETALLES



PISTOLA MANUAL



VÁLVULA DE FONDO



PINZAS

## COMPONENTES

- BOMBA:
  - SUZZARABLUÉ PUMP AC PÁG. 70
  - SUZZARABLUÉ PUMP DC PÁG. 72
- PISTOLA:
  - SUZZARABLUÉ MANUAL NOZZLE PÁG. 120

## FICHA TÉCNICA

CÓDIGO	DESCRIPCIÓN	TIPO DE FLUIDO	CAUDAL		TENSIÓN			PISTOLA	MANGUERA		ON/OFF
			L/MIN	GPM	CA V/HZ CC VOLT	POTENCIA WATT	AMP. MAX.		TYPE	LONGITUD	
FOO201AAA	SUZZARABLUÉ KIT 12V		35	9,2	12	260	22	MANUAL	6 M	3/4"	Si
FOO201C7A	SUZZARABLUÉ KIT 230 V		32	8,5	230/50	400	1,95	MANUAL	6 M	3/4"	Si

# SUZZARABLUÉ PORTABLE KIT

PORTÁTIL

61